

Aero Big & Tall













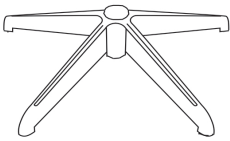

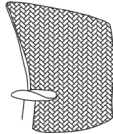
SCAN HERE
to see additional
information and
product videos

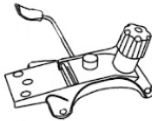

Tools Required

Allen key provided.
No additional tools required.

Parts Included

				
A x 1 Base	B x 1 Seat Pan	C x 2 Armrests	D x 1 Backrest	E x 5 Casters
				
F x 5 Mechanism	G x 1 Gaslift	M6 x 25 H x 2	M6 x 30 I x 8	M8 x 20 J x 3
				
		M6 K x 10	M8 L x 3	M x 3
				
				0.5 N x 2

Step 1

Insert casters into base. Insert gaslift into base.

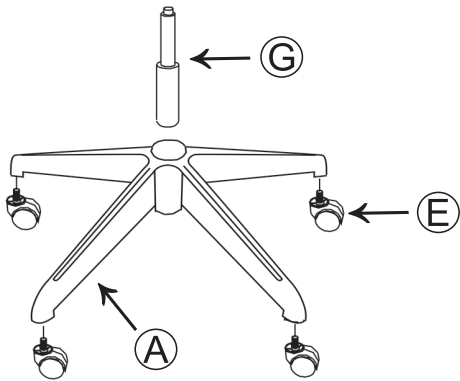

Step 2

With seat pan upside down, attach armrests marked L (left) and R (Right) to seat using screws (I) & washers (K) shown below and tighten with Allen Key.

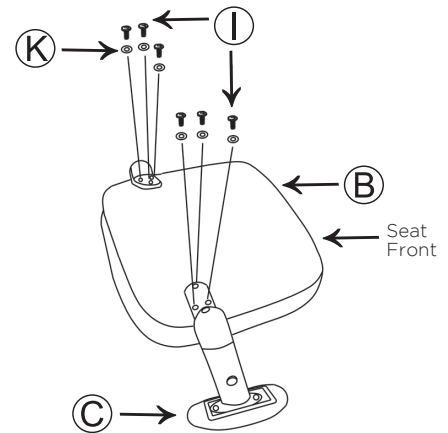

Step 3

With seat upside down, place mechanism on the seat aligning so the "Front" label on the mechanism matches the Front label on the seat pan. Use 2 screws marked (H) and two screws marked (I) and flat washers (K) to attach the mechanism. Tighten fasteners once all fasteners are in using Allen Key.

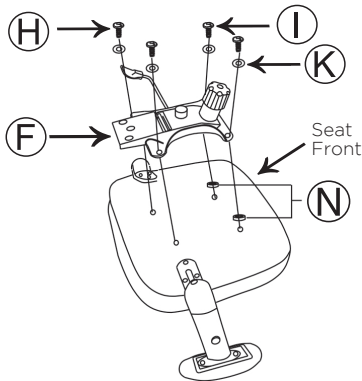

Step 4

Attach backrest to mechanism using 3 back screws and washers shown below, tighten screws using Allen Key.

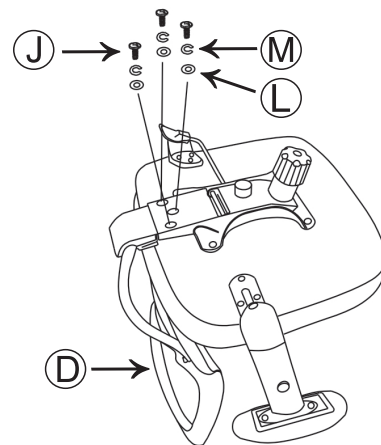

Step 5

Attach assembled chair to base and gaslift. Sit on the chair to secure.

